

660 LITRE CONTAINER: A FRESH LOOK AT AN OLD FAVOURITE



**EASY HANDLING
MAXIMUM SAFETY
ATTRACTIVE DESIGN**

Easy handling

- Easy grip handles on all sides
- For easy filling
- For safe manoeuvring



Reinforced base

- Ensures stability even when fully loaded
- Very stable wheel assemblies



Maximum safety

- Specially developed lifting trunnions (for 660 and 770 litre containers)
- Increased safety when lifting



660 litre container

Material

■ Polymer components:

- Injection moulded from specially designed HDPE
- Resistant to decay, frost, heat and chemicals
- Special UV-stabilisation provides excellent ageing characteristics

■ Corrosion resistant metal components:

- All metal components are galvanised

■ Noise reduction:

- Quiet-running tyres

■ Long service life:

- High quality materials
- Most advanced manufacturing processes
- Even if exposed to high mechanical stress levels

■ Recycling:

- All container parts are recyclable

Advantages

- Easy handling
- Easy filling
- Easy grip handles on front and sides of lid
- Stable and light weight lid
- Safe manoeuvring
- Easy grip handles on three sides
- Wide handles, easy to use when wearing thick gloves
- User-friendly handles
- Handles available in alternative colours
- Complies fully with EN or RAL quality requirements
- Versatile, with a comprehensive accessories range
- Various wheel assembly configurations for different applications
- Water drainage plug as standard
- Compatible with identification and weighing systems
- Suitable for all lifting equipment in accordance with EN 840
- Rounded lid profile for improved rainwater dispersal

Dimensions and Weights

- Nominal volume: 660 litres
- Net weight: ca. 43 kg
- Permitted total weight: 310 kg

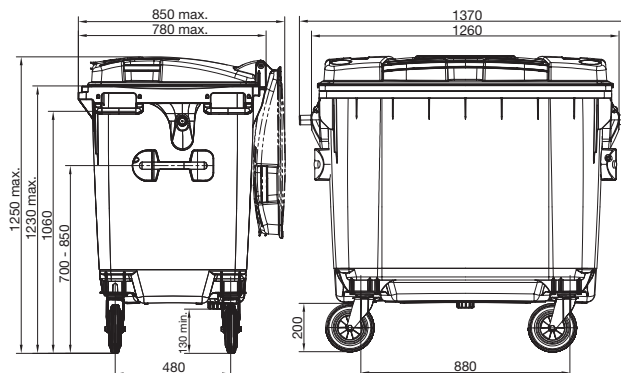

all dimensions according to EN 840

Colours

- Standard colours: grey, green, blue, yellow, brown, red
- Special colours are available on request
- All additives are cadmium free and environmentally friendly

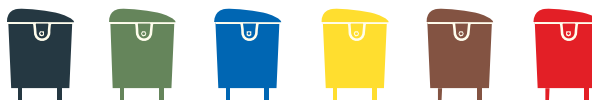

Imprints and markings

- Manufacturer
- Month and year of manufacture
- Nominal volume, max. permitted total weight
- "No hot ashes" symbol
- Material
- EN 840, RAL markings
- Individual markings with imprints, screen printing, hot-foil printing or adhesive labels

Accessories

- For accessories and special design variations such as lid apertures, locks, towing brackets and fork lift sleeves, please refer to the separate accessories sheet for 4-wheeled containers



SULO

SULO Umwelttechnik GmbH & Co. KG
Bünder Straße 85
D-32051 Herford
Telefon +49 (0) 52 21 598-207
Telefax +49 (0) 52 21 598-579
Internet: www.sulo.com
e-mail: info@sulo.de