

1100 LITRE FLAT LID CONTAINER: THE BEST IN ITS CLASS



**UNIQUE DESIGN
EASY HANDLING
IMPROVED SAFETY**

Improved handling

- Easy grip handles on all sides
- Optimum manoeuvrability



Increased safety

- Foot pedals on the front wheels prevent rotating and swivelling
- Increased stability



Benefits

- Accessories easily fitted
- Complies to EN840 standard
- Safe and easy handling



1100 Litre Flat Lid Container

Material

- **Polymer components:**
 - Injection moulded from specially designed HDPE
 - Resistant to decay, frost, heat and chemicals
 - Special UV-stabilisers provide excellent ageing characteristics
- **Corrosion resistant steel components:**
 - Wheel forks, wheel bearings, swivel brackets, lid retention springs and screws from galvanised steel. No maintenance necessary.
- **Noise reduction:**
 - Wheel assemblies with solid rubber tyres
- **Long service life:**
 - High quality materials
 - Excellent manufacturing processes
 - Withstands exposure to high mechanical stress levels
- **Recycling:**
 - All container parts are recyclable

Design

ADVANTAGES FOR THE USER:

- Easy handling through the use of ergonomic handles
- Versatile, with a comprehensive accessories range
- In accordance with the safety requirements of EN-840

ADVANTAGES FOR THE COLLECTOR:

- Easy grip handles on all sides
- Safe, easy handling, even with heavy loads
- Various wheel assembly configurations for different applications
- Improved water drainage as a result of rounded lids
- Water drainage plug as standard†
- Compatible with identification and weighing systems

Accessories

- For accessories and special design variations such as lid apertures, locks, towing brackets and fork lift sleeves, please refer to the separate accessories sheet for 4-wheeled containers

Dimensions - Weights - Standards

- Nominal volume: 1100 litres
- Net weight: approx. 65 kg
- Max. load: 440 kg
- Permitted total weight: 510 kg

measurements to be used as a guide only -variations will occur

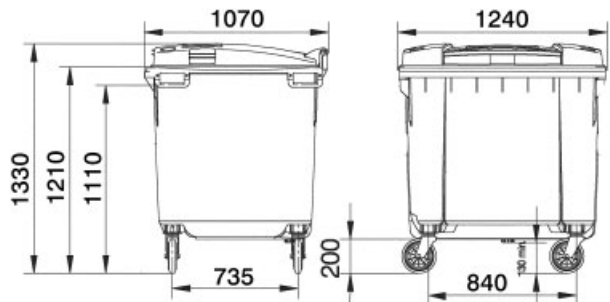

nominal dimensions



Colours

- Standard colours: green, blue, yellow
- Special colours are available on request*
- All additives are cadmium free and environmentally friendly



Imprints and markings

- Manufacturer, year of manufacture, material
- Nominal volume, max. permitted total weight
- EN 840, RAL markings
- Individual markings with imprints, screen printing, hot-foil printing or adhesive labels available on request *



Sulo MGB Australia Pty Ltd
123 Wisemans Ferry Road
Somersby NSW 2250
AUSTRALIA

Telephone: +61 (0) 2 - 4348 8188
Facsimile: +61 (0) 2 - 4348 8128
Internet: www.sulo.com.au
E-mail: info@sulo.com.au

Sulo – Queensland Office
11 Argon Street
Sumner Park QLD 4070
AUSTRALIA

Telephone: +61 (0) 7 - 3725 5000
Facsimile: +61 (0) 7 - 3725 5099

Sulo – Victorian Office
6 Capital Link Drive
Campbellfield VIC 3061
AUSTRALIA

Telephone: +61 (0) 3 - 9357 7320
Facsimile: +61 (0) 3 - 9357 7340