

140 LITRE KOMPAKT CONTAINER: SIMPLY A BETTER BIN



EASY HANDLING
VERSATILE
STABLE DESIGN

Designed for local market

- Stable on uneven surfaces and against wind
- Larger footprint increases stability
- Lower centre of gravity



Multiple applications

- Part of a multi-bin system
- Assists with waste reduction goals but with the look of a larger container
- Ideal for homes, units, multi-occupancy dwellings and offices



Improved design features

- Larger opening and body
- Non-impact lid that reduces noise
- Internal concave floor assists emptying



140 Litre Container

Material

- **Polymer components:**
 - Injection moulded from specially designed HDPE
 - Resistant to decay, frost, heat and chemicals
 - Special UV-stabilisation provides excellent ageing characteristics
- **Corrosion resistant metal components:**
 - Solid, galvanised steel axle
- **Noise reduction:**
 - Quiet-running solid rubber tyres
 - Tight-fitting axle
- **Long service life:**
 - High quality materials
 - Most advanced manufacturing processes
 - Withstands exposure to high mechanical stress levels
- **Recycling:**
 - All container parts are recyclable

Advantages

- Easy to manoeuvre
- Versatile, with a comprehensive accessories range
- Complies fully with EN or RAL quality requirements
- Open wheel case prevents accumulation of dirt
- Particularly stable due to external position of wheels
- Safe and easy to handle
- Suitable for all DIN lifting equipment
- Double angle rail for greater safety when emptying
- Compatible with identification and weighing systems
- Special ribs prevent containers from becoming jammed when stacked

Imprints and markings

- Manufacturer, year of manufacture, material
- Nominal volume, max permitted total weight
- EN 840, RAL markings
- Individual markings with imprints, screen printing, hot-foil printing or adhesive labels
- Customer specific serial numbers if required

Accessories

- For accessories and special design variations such as lid apertures, locks etc, please refer to the separate accessories sheet for 2-wheeled containers

SULO

Sulo MGB Australia Pty Ltd
 123 Wisemans Ferry Road
 Somersby NSW 2250
 AUSTRALIA
 Telephone: + 61 (0) 2 - 4348 8188
 Facsimile: + 61 (0) 2 - 4348 8128
 Internet: www.sulo.com.au
 E-mail: info@sulo.com.au

Sulo – Queensland office
 11 Argon Street
 Sumner Park QLD 4074
 AUSTRALIA
 Telephone: + 61 (0) 7 - 3271 9800
 Facsimile: + 61 (0) 7 - 3271 9813

Sulo – Victorian office
 6 Capital Link Drive
 Campbellfield VIC 3061
 AUSTRALIA
 Telephone: + 61 (0) 3 - 9357 7320
 Facsimile: + 61 (0) 3 - 9357 7340

Dimensions - Weights - Standards

- Nominal volume: 140 litres
 - Net weight: approx 10.4 kg
 - Max load: 56 kg
 - Permitted total weight: 70 kg
- | | | | | | |
|-----|--------|-----|--------|-----|--------|
| ■ A | 925 mm | ■ D | 615 mm | ■ G | 505 mm |
| ■ B | 870 mm | ■ E | 535 mm | | |
| ■ C | 550 mm | ■ F | 395 mm | | |

Measurements to be used as a guide only – variations will occur

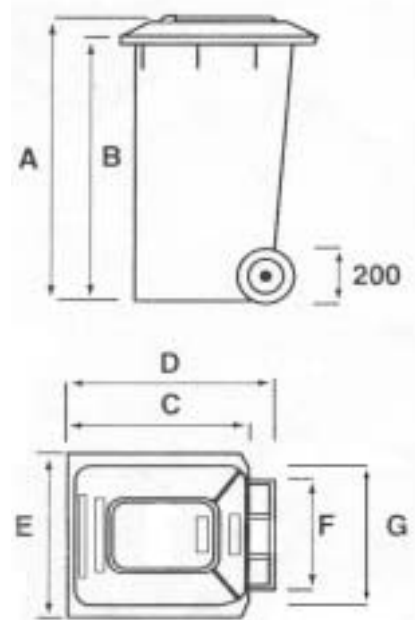

According to EN 840-5, 6

Colours

- Standard colours: nature green, dark green, grey
- Special colours are available on request – common colours include blue, yellow, red, brown, orange

