

Multi Stack Lifter

The SULO multi stack lifter fork lift truck (FLT) attachment is designed to assist in the safe handling of 2 and 4 wheel Mobile Garbage Bins (MGBs). The FLT attachment enables multiple MGB stacks to be easily lifted and relocated in a safe and efficient manner. The attachment is suitable for use on 80, 120, 140, 240 360, 660 and 1100 litre MGBs and is fitted with counterweighted fork tyne locks for maximum safety.

The product bears an engineering compliance plate detailing the individual product's design and compliance to AS 2359.6-1995 Powered Industrial Trucks - Safety Code.

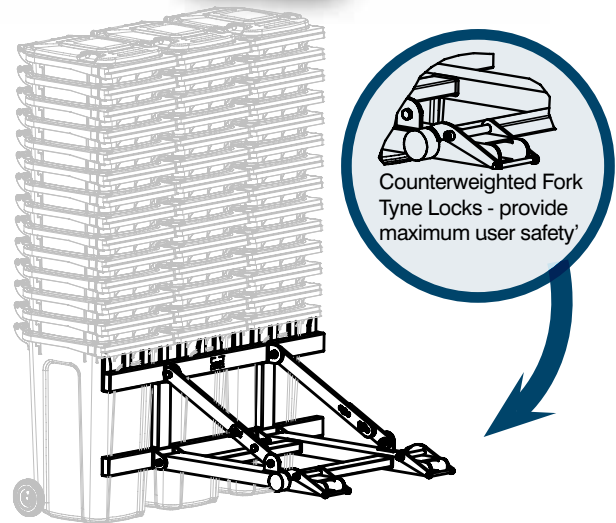
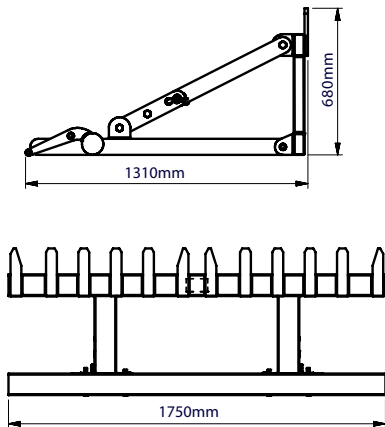

PRODUCT SPECIFICATIONS

Safe Working Load (SWL): 525kg
 Load centre: 710mm
 Unit weight: 155kg
 Tyne pocket size: 130mm x 65mm
 Tyne pocket centres: 850mm
 Finish: Corrosion protected

STANDARD LIFTING CONFIGURATION x BIN SIZE

BIN SIZE	STD STACK QTY	APPROX STACK HEIGHT (mm)	APPROX STACK WEIGHT (kg)	MAX No STACKS	APPROX TOTAL LIFT WEIGHT (kg)
80L	14	2540	56	4	224
120L	14	2690	84	4	336
140L	14	2690	96	3	288
240L	14	2690	124	3	372
360L	12	2590	141	3	423
660L	5	2650	215	1	215
1100L	5	2650	325	1	325

SULO MGB Australia
 123 Wisemans Ferry Road
 Somersby NSW 2250 Australia
 T: (02) 4348 8188
 F: (02) 4348 8128

SULO – Queensland Office
 11 Argon Street
 Sumner Park QLD 4074
 Australia
 T: (07) 3725 5000
 F: (07) 3725 5099

SULO – Victorian Office
 1950 Hume Hwy
 Campbellfield VIC 3061
 Australia
 T: (03) 9357 7320
 F: (03) 9357 7340

SULO Talbot - New Zealand
 Gate 4, 13 Kerwyn Avenue
 East Tamaki, Auckland 2141
 New Zealand
 T: (09) 968 2180
 F: (09) 968 2188