

2-Wheeled Container Systems

60 Litre Mobile Garbage Bin: For waste reduction in urban areas

The innovative SULO 60 Litre MGB has been specifically designed for waste reduction within urban spaces consisting of high density living and built up inner city areas. Designed with the urban user in mind and manufactured in Australia, the 60 Litre MGB is available in a standard or RETRO option and provides a compact wheelie bin that can fit into small spaces.

- EASY HANDLING
- VERSATILE
- STABLE DESIGN

The 60 Litre MGB is suitable for a number of applications including;

- Food waste collection, including at the kerbside
- Apartment blocks or housing areas
- Commercial kitchens
- Clinical waste
- General waste
- Battery disposal
- Glass collection
- Hospitality
- Large office blocks
- General storage



Versatile handle#:
Extends for user comfort and folds flat for easy storage

#Patents applied for



Footstep at rear:
Allows the bin to be easily tilted



Optional Gravity Latch#:
Automatically secures the lid shut when sitting vertical



Aerated lid handles:
Allows air to flow through the closed MGB reducing the weight when used for organic waste

60 litre Standard MGB

- Weight: 6.19kg with 200mm wheels
- Volume: 60 litres
- Max Load: 24kg

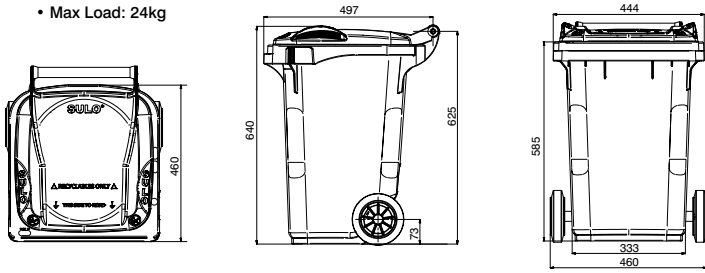

60 Litre RETRO MGB

- Weight: 6.44kg with 200mm wheels
- Volume: 60 litres
- Max Load: 24kg

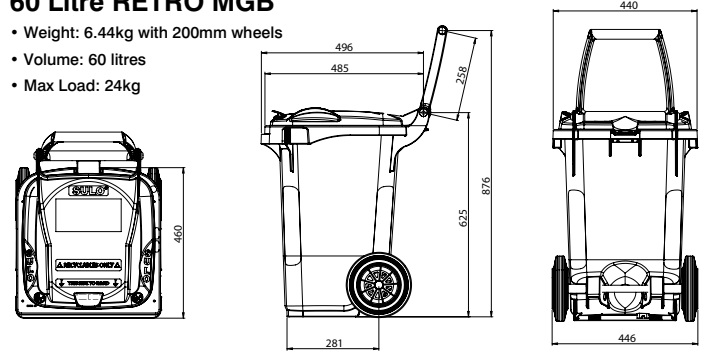

Versatile handle;

Extends the handle to a height of 878mm, ensuring maximum comfort as the user is not required to bend over when wheeling the bin. Handle can also be folded forward to hold the lid shut and can be stored in small spaces

Modern, streamlined lid;
Allows for an increased customisation area

Optional gravity latch;

Automatically secures the lid shut when sitting vertical and automatically unlatches when tilted to a 90 degree angle, such as during emptying

Latch for extendable handle;
Locks the handle in upright position for easy manoeuvrability

Compostable bags available



Flat surface;

For the application of customer markings including hot stamping and labels

Made in Australia with up to 35% recycled content

Textured surface;
For increased grip during lifting

Optional venting in lid handles;

Allows air to flow through the closed MGB, reducing the weight of the contents when used for organic waste

Footstep at rear of bin;

Allows the bin to be easily tilted for wheeling



200mm wheel;

For increased stability during manoeuvring. Rubber tyres reduce noise when wheeled.

Colours

- Standard colours: black, nature green, dark green, grey
- Non-Standard colours: red, yellow, blue, lime green
- Additional colours available upon request: minimum order quantity applies



SULO MGB Australia
123 Wisemans Ferry Road
Somersby NSW 2250 Australia
T: (02) 4348 8188
F: (02) 4348 8128

SULO – Queensland
11 Argon Street
Sumner Park QLD 4074 Australia
T: (07) 3725 5000
F: (07) 3725 5099

SULO – Victoria
1950 Hume Hwy
Campbellfield VIC 3061 Australia
T: (03) 9357 7320
F: (03) 9357 7340

SULO®

ENVIRONMENTAL TECHNOLOGY

www.sulo.com.au info@sulo.com.au